

管状熔断体

Cartridge Fuse-links (CFL)

SCT520(P)系列 Series, 慢断 Time-Lag, 陶瓷管 Ceramic Tube

尺寸 Dimensions (mm)

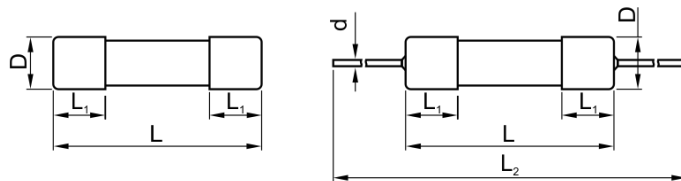

L	L ₁	L ₂	D	d
20.0 ± 0.5	5.1 ± 0.3	96 ± 2	Φ5.20 ^{+0.1} _{-0.2}	≤6.3 A: Φ0.65 ± 0.05 >6.3 A ~ 10 A: Φ0.80 ± 0.05 >10 A ~ 20 A: Φ1.00 ± 0.05 25 A / 30 A: Φ1.20 ± 0.05

关键特性 Key Features

- 外形尺寸: Φ5 mm × 20 mm
Physical Size: Φ5 mm × 20 mm
- 慢断 Time-Lag
- 高分断能力 High Breaking Capacity
- 陶瓷管, 镀镍黄铜帽结构
Ceramic Tube, Nickel-plated Brass Endcap Construction
- 执行标准: UL248-14 / IEC60127-2 & 7
Designed To UL248-14 / IEC60127-2 & 7
- 无铅 Lead-free (Pb-free)
- 环保型产品 RoHS & REACH Compliant

应用 Applications

- 电源 Power Supply
- 家电 Household Appliance
- 防雷器 SPD
- 通用照明 General Lighting
- 智能家居 Smart Home
- 办公设备 Office Equipment
- 电动工具 Electric Tool
- 医疗设备 Medical Equipment

结构图 Structure

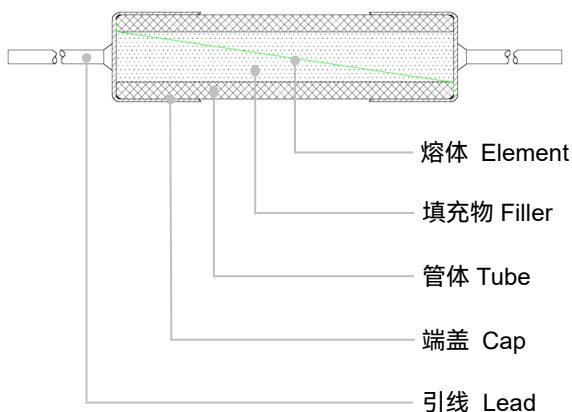

型号说明 Product Number System

SCT520T3.15A250V

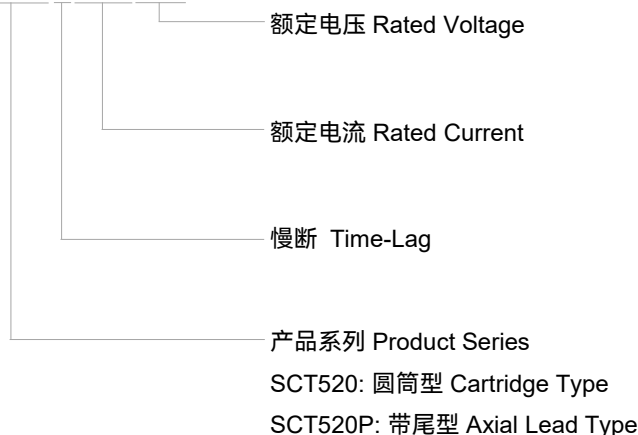

安规认证 Agency Approvals

安规认证 Agency Approvals	认证号 Agency File Number	电流范围 Ampere Range
	E345932	0.4 A ~ 30 A
	CQC21012316337 CQC21012316630 CQC21012324758 CQC21012325082	0.4 A ~ 20 A
	R50575995 R50576001 R50538205 R50538319	0.8 A ~ 2.5 A 3.15 A ~ 4 A 5 A ~ 8 A 10 A ~ 20 A

术语 Glossary

项目 Item	描述 Description
熔断器 Fuse	<p>一种装置，当通过该装置的电流超过规定值，并持续足够的时间，该装置中一个或多个经特殊设计、特殊配比的部件熔断，断开其所接入的电路，从而切断电流。</p> <p>A device, by the fusing of one or more of its specially designed and proportioned components, opens the circuit in which it is inserted by breaking the current when this exceeds a given value for a sufficient time.</p> <p>—(IEC 60127)</p>
额定电流 Rated Current	<p>熔断器的额定电流是根据其可控制测试条件的截流能力确定的。每个熔断器上都应标上额定电流，它可以是数字、字母、或色码。</p> <p>The rated current of a fuse identifies its current-carrying capacity based on a controllable set of test conditions. Each fuse is marked with its rated current, this rating can be identified with a numeric, alpha, or color code mark.</p> <p>—(IEC 60127)</p>
额定电压 Rated Voltage	<p>熔断器可以使用的最大安全开断电压，超过额定电压将影响断开过载和短路电路的能力。</p> <p>A Max. open circuit voltage in which a fuse can be used, yet safely interrupt an overcurrent. Exceeding the voltage rating of a fuse impairs its ability to clear an overload or short circuit safely.</p> <p>—(IEC 60127)</p>
标称熔化热能 Ampere Squared Seconds I^2t	<p>在电流平方对给定时间间隔的积分，被称为I^2t。它是熔断所需的热能。熔断I^2t可以是熔化I^2t，飞弧I^2t，或二者之和。</p> <p>The melting, arcing, or clearing integral of a fuse, termed I^2t, is the thermal energy required to melt, arc, or clear a specific current. It can be expressed as melting I^2t, arcing I^2t or the sum of them, clearing I^2t.</p> <p>—(IEC 60127)</p>
过载 Overload	<p>电流超过额定负荷的2到5倍，且保持正常的电流路径。</p> <p>Can be classified as an overcurrent which exceeds the normal full load current of a circuit by 2 to 5 times its magnitude and stays within the normal current path.</p> <p>—(UL 248)</p>
过电流 Overcurrent	<p>在一个电路中，超过正常负载电流的电流称为过电流。过电流包括过载电流和短路电流。</p> <p>A condition which exists in an electrical circuit when the normal load current is exceeded. Overcurrent take on two separate characteristics-overloads and short circuits.</p> <p>—(UL 248)</p>
短路 Short Circuit	<p>将短路是电流不流过正常电路而引起的过电流，它大大超出了正常满载电流数十、数百甚至数千倍。</p> <p>An overcurrent that leaves the normal current path and greatly exceeds the normal full load current of the circuit by a factor of tens, hundreds, or thousands times.</p> <p>—(UL 248)</p>
分断能力 Breaking Capacity of a Fuse-link	<p>在规定的使用和性能条件下，熔断器在规定电压下能分断的预期电流值（对交流为有效值）。</p> <p>Value (r.m.s. for AC) of prospective current that a fuse-link is capable of breaking at a stated voltage under prescribed conditions of use and behaviour.</p> <p>—(IEC 60127)</p>

Miniature Fuses



Miniature Fuses

管状熔断体

Cartridge Fuse-links (CFL)

SCT520(P)系列 Series, 慢断 Time-Lag, 陶瓷管 Ceramic Tube

技术参数 Specifications

系列 Series	额定电流 Rated Current (A)	额定分断能力 Rated Breaking Capacity	平均熔化热能值 Average Typical Melting I^2t^a (A ² sec)	安规认证 Agency Approvals			环境 Environmental	
				 CQC	 TUV	 cURus	RoHS	REACH
SCT520 SCT520P	0.4	UL (0.4 A - 10 A): 10 kA@250 VAC 300 A@400 VAC 200 A@500 VAC SCT520P: 2 kA@300 VAC SCT520: 1500 A@300 VAC 3 kA@300 VDC 500 A@500 VDC UL (12.5 A - 20 A): 1 kA@250 VAC SCT520P: 300 A@500 VAC SCT520: 500 A@400 VAC 500 A@300 VDC UL (25 A - 30 A): SCT520P: 500 A@250 VAC SCT520: 500 A@300 VAC CQC/TUV (0.4 A - 10 A): 5 kA@250 VDC 3 kA@300 VDC 500 A@500 VDC 1500 A@250 VAC 300 A@400 VAC 200 A@500 VAC CQC/TUV (12.5 A - 20 A): 500 A@300 VDC 1 kA@250 VAC 300 A@400 VAC	0.06	●		●	●	●
SCT520 SCT520P	0.5		0.14	●		●	●	●
SCT520 SCT520P	0.63		0.23	●		●	●	●
SCT520 SCT520P	0.8		0.96	●	●	●	●	●
SCT520 SCT520P	1		2.2	●	●	●	●	●
SCT520 SCT520P	1.25		4.7	●	●	●	●	●
SCT520 SCT520P	1.6		10.2	●	●	●	●	●
SCT520 SCT520P	2		20	●	●	●	●	●
SCT520 SCT520P	2.5		31	●	●	●	●	●
SCT520 SCT520P	3		55	●		●	●	●
SCT520 SCT520P	3.15		59	●	●	●	●	●
SCT520 SCT520P	4		96	●	●	●	●	●
SCT520 SCT520P	5		75	●	●	●	●	●
SCT520 SCT520P	6.3		146	●	●	●	●	●
SCT520 SCT520P	8		256	●	●	●	●	●
SCT520 SCT520P	10		500	●	●	●	●	●
SCT520 SCT520P	12.5		820	●	●	●	●	●
SCT520 SCT520P	15		1280			●	●	●
SCT520 SCT520P	16		1792	●	●	●	●	●
SCT520 SCT520P	20		2800	●	●	●	●	●
SCT520 SCT520P	25	3100			●	●	●	
SCT520 SCT520P	30	4500			●	●	●	

a: I^2t 是在10倍额定电流测试下得到的。 I^2t value is measured at 10 I_N .

o: 待定 Pending

管状熔断体

Cartridge Fuse-links (CFL)

SCT520(P)系列 Series, 慢断 Time-Lag, 陶瓷管 Ceramic Tube

熔断特性 Pre-arcing Time/Current Characteristic

额定电流 Rated Current	2.1I _N		2.75I _N		4I _N		10I _N	
	最大 Max.	最小 Min.	最大 Max.	最小 Min.	最大 Max.	最小 Min.	最大 Max.	
0.4 A ~ 0.8 A	30 minutes	250 ms	80 s	50 ms	5 s	5 ms	150 ms	
1 A ~ 3.15 A	30 minutes	750 ms	80 s	95 ms	5 s	10 ms	150 ms	
4 A ~ 10 A	30 minutes	750 ms	80 s	150 ms	5 s	10 ms	150 ms	
12 A ~ 30 A	30 minutes	750 ms	80 s	150 ms	8 s	10 ms	150 ms	

时间电流特性曲线 Time Current Curve (仅供参考 For Reference Only)

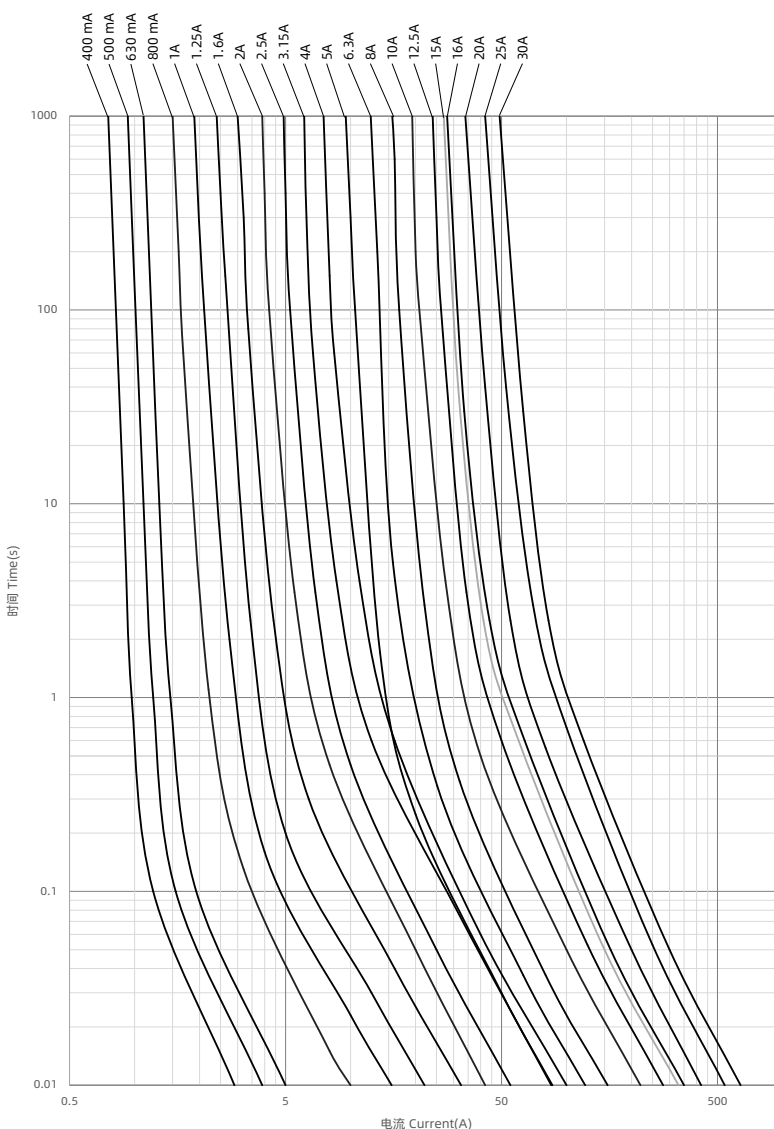

Miniature Fuses

Miniature Fuses

管状熔断体

Cartridge Fuse-links (CFL)

SCT520(P)系列 Series, 慢断 Time-Lag, 陶瓷管 Ceramic Tube

包装信息 Packaging Information

尺寸 Dimensions (mm)

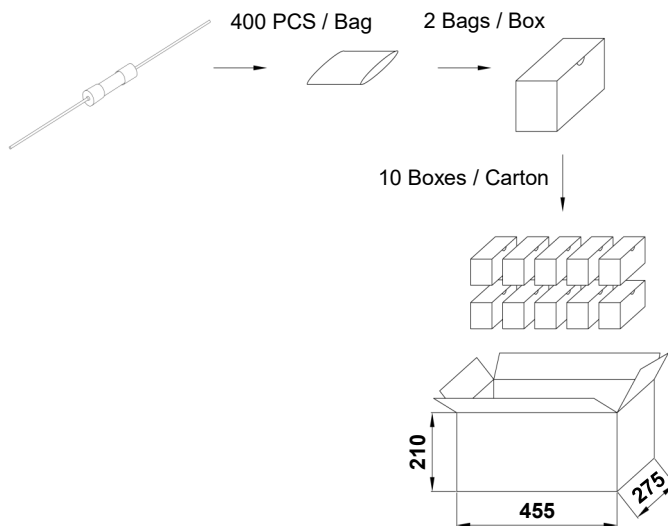
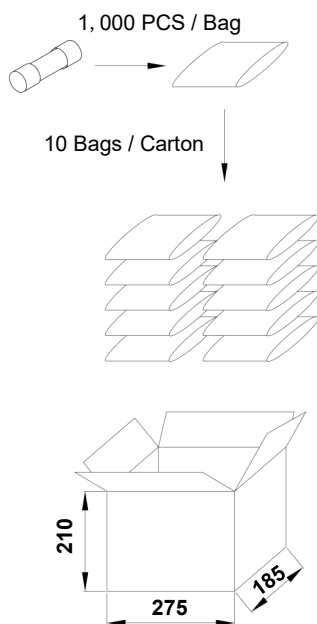

圆筒型 Cartridge Type		
项目 Item	PE袋 Bag	箱 Carton
数量 Q'ty (PCS)	1,000	10,000
毛重 Gross Weight (kg)	13.5×(1±10%)	

带尾型 Axial Lead Type			
项目 Item	PE袋 Bag	盒 Box	箱 Carton
数量 Q'ty (PCS)	400	800	8,000
毛重 Gross Weight (kg)	15×(1±10%)		

Miniature Fuses

Miniature Fuses



注意

ATTENTION

检测 Inspection

冷电阻测试 Cold Resistance Test

a. 环境温度为 (23 ± 2) °C, 测试电流不大于熔断器额定电流的10%。

Applied current shall be less than 10% of rated current, at ambient Temp. of (23 ± 2) °C.

b. 采用四端测试法 (4-Wire) Resistance Measurement.

使用 Usage

a. 通电情况下请勿直接触碰熔断器本体或引线, 防止烫伤或触电。

Do not touch the fuse body or lead wire when power on, avoiding scald or electric shock.

b. 气压在80 kPa 到106 kPa, 对应海拔为+2000 m至- 500 m。

Air pressure is 80 kPa to 106 kPa. These values represent an altitude of +2000 m to -500 m, respectively.

更换 Replacement

基于安全原因, 熔断器是不可修复的产品, 替换时应使用同类别同型号的产品。

For safety reasons, the Fuse is the non-resettable product, please ensure that the alternative Fuse is the same type when replace it.

贮存 Storage

熔断器的贮存应避免高温、高湿、日光直射和腐蚀性气体的场合, 以免影响引脚可焊性, 产品购入后请于1年内使用完毕。

Please store the fuse in the environment without high temperature, high humidity or corrosive gas, to avoid reducing the solderability of the lead wire. Please use them up within 1 year after receiving the goods.

管状熔断体

Cartridge Fuse-links (CFL)

SCT520(P)系列 Series, 慢断 Time-Lag, 陶瓷管 Ceramic Tube

安装 Installation

机械应力 Mechanical stress

安装过程和安装后不宜对熔断器本体施加机械应力。

Do not apply mechanical stress to the fuse body during or after the installation.

焊接参数 Soldering Parameters

波峰焊参数 Wave soldering Parameters (仅供参考 For Reference Only)



表3 TABLE 3

项目 Item	温度 Temp. (°C)	时间 Time (s)
预热 Preheating	100 - 150	60 - 180
过锡 Dwelling	255 - 265	4 - 8

推荐的手工焊参数 Recommended Soldering Parameters

烙铁温度 Solder Iron Temp.: $(350 \pm 5) ^\circ\text{C}$

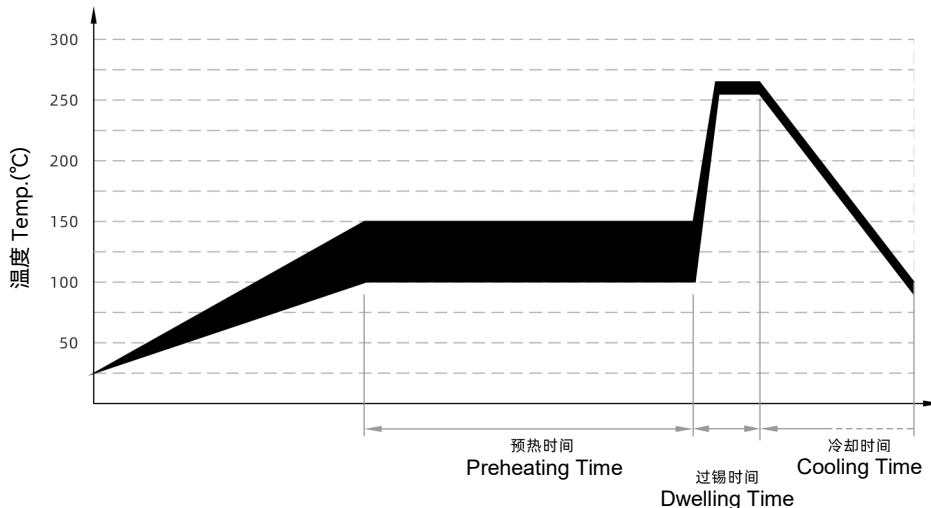
焊接时间 Soldering Time: $\leq 5 \text{ s}$

引脚弯曲 Lead Wire Bending

如果要弯折引脚，那么应确保弯折处与主体间的距离，如下表。

If the lead wire has to be bent, please pay attention to the distance between body and the bending point. Refer to the following table.

表4 TABLE 4

轴向型 Axial Type			
d	$\leq \Phi 1.0 \text{ mm}$	$> \Phi 1.0 \text{ mm}$	
L	$\geq 3 \text{ mm}$	$\geq 5 \text{ mm}$	

安装位置 Installation Position

勿将熔断器安装在可能经常出现剧烈振动的位置。

Do not install the fuse on a location that may often subject to severe continuous vibration.